

Construction Methods and Specifications

1. **Footings:** Attached deck footings shall be on a firm soil base excavated to at least 42 (forty-two) inches below grade. Wooden posts are not recommended to be encased below grade with concrete.

2. **Floor Framing:** Floor joist spans are based on 10 lb. dead load and 30 lb. live load, #2 southern yellow pine. Refer to NYS Residential Building Code for uses of other grades/ species of wood per NYSRC Table 502.3.1(1) 2007.

Joist spacing	16"oc	24"oc
2x6	10'5"	8'6"
2x8	13'6"	11'0"
2x10	16'0"	13'0"

3. **Girders/Beams:** Recommended spans are based on fabricated double members supporting floor joist between post. Girders/beams to be through bolted to posts or other secure methods as approved.

- 2 2x6 = 4' to 5' between posts
- 2 2x8 = 6' to 7' between posts
- 2 2x10 = 7' to 8' between posts

4. **Cantilever Spans:** A full-depth rim joist shall be provided. Solid blocking shall be provided at the cantilevered support.

2x6	cantilever not permitted	
2x8	16"oc	34"
2x10	16"oc	49"

5. **Posts or Columns** three (3) feet or greater above grade may require diagonal bracing installed to prevent buckling or twisting. Alternatively, structural columns or posts of greater diameter may be used.

6. **Attachment:** Ledgers, boards, girders, or beams which are attached to exterior walls or posts shall be secured by bolts or lag fasteners or other approved methods. Joists framed into the sides of ledger boards, girders or beams shall be supported by hangers or ledger strips. Ledger boards attached to buildings require two rows of staggered ½" bolts or lags at 12-14" oc and require flashings installed to prevent water exposure to the building structure. All-weather exposed lumber and fasteners shall be corrosion-resistive or made of other approved materials.

7. **Steps:** Steps greater than 3 risers high require a handrail thirty-four (34) inches in height on at least one side of the steps. Handrails require a 1 ¼" to 2" circular gripping area design. Treads and risers are to be uniform in height and width. Treads shall be 9" in width. Risers are to be 8 ¼" in height, shall be of closed back design and shall have no opening greater than 4".

8. **Railings:** Raised floors above 30" from grade require railings be a minimum of thirty-six (36) inches in height with all vertical and horizontal openings being no greater than 4" clear space.

Information Resources

Methods of construction are based on code requirements of the NYS Uniform Residential Building Code and generally accepted methods. Where discrepancies exist between this publication and commonly accepted practices, consult with the Building Department.

Notice and Disclaimer

This brochure was prepared to address the most commonly asked questions and does not attempt to list all applicable requirements.

Safety Information

**Improperly built decks can be dangerous.

**Charcoal or ember-producing cooking and/or heating appliances should not be used on any wooden decks.

**Use of electrical devices such as stereos, lighting, etc., should only be connected to ground-fault protected (GFI) outlets.

Existing Decks

**Life expectancy of a deck is 10-20 years and can be past their useful life. When inspecting a deck, look at:

- Missing connectors
- Loose/wobbling connections
- Rot or corrosion
- Excessive cracking or buckling

** If you are seeking a permit for an existing deck for a property sale, there is a \$45 field inspection review fee. Existing decks shall comply with the most closely applicable safety and code requirements as practicable. Certificate of Compliance is required to close out any application issued.

Village of Brockport

Building Department

127 Main St • Brockport, NY 14420

Phone: 585-637-5300 x114

Fax: 585-637-1045

Email: cfabry@brockportny.org

Website: www.brockportny.org

Village of Brockport

DECKS &

POOL DECKS

Residential

Permit Type: _____

Address: _____

Date Issued: _____

A deck is a structure which forms a level, roofless walking surface. Most commonly, decks above 30" from grade and greater than 50 square feet in area require a building permit and may be classified as:

- Attached decks
- Free-standing decks
- Pool decks
- Pre-manufactured decks
- Stoops or porches

Do decks really need to meet code? Because they look relatively simple to build, many people do not realize that decks are structures that need to be designed to adequately resist stresses. Like a home, a deck must be designed to support the weight of people and objects placed on the deck, as well as weather factors. It must be constructed using sound building practices.

Permits

To obtain a permit for the construction or erection of a new or replacement deck, the following information must be provided with a completed application form:

- A tape map or instrument survey property map showing the scaled location of the proposed deck and all other structures, easements and overhead power lines.

- One set of construction drawings. These drawings must show the floor plan and cross sections of the deck. Note material types and sizes, methods of attachments, railing and step construction and other techniques used.

- Contractors are required to have proper insurance coverage during the project. The Building Department may request documentation of insurance.

Inspections

1. Deck footing inspections are not required. However, footer depth documentation is recommended if, in the future, the deck may support additional structures (i.e. sunroom, porch.)

2. An inspection is required after completion of the deck. Upon approval by the Building Department, a Certificate of Compliance will be issued. If a deficiency is found, a written report will be issued stating the compliance needs and re-inspection requirements.

3. An electrical inspection by a licensed inspection agency is required if the deck will be serviced by new outlets or lighting.

Electrical Inspection Agencies:

Commonwealth Elec. Insp. Svc. (585) 624-2380

Middle Department Inspection (585) 454-5191

New York Elec. Insp. Agency (585) 436-4460

Locating a deck

1. Deck setbacks from property lines are established by the Zoning requirements of the Village of Brockport. Generally, decks located entirely within a rear yard must be located a distance no less than 3 (three) feet from a property line. All accessory structures cannot be located in any easements or drainage swales unless prior approval is granted by the authority having jurisdiction.

Additionally, no wooden structure can be closer than 4 (four) feet to any property line as required by the NYS Building Code.

2. Lot coverage limitations are the sum of the area of all structures on the property added together and divided into the total size. If all the structures, such as house, pool, sheds, etc. do not exceed 30% lot coverage, then the proposed deck may be installed.

3. Overhead service electric wires shall have a minimum vertical clearance of 10 (ten) feet from the walking surface of the deck or as deemed adequate and safe by the electricity supplying authority.

4. Prior to construction, underground utilities must be located and marked out to assure the proposed work will not result in an accidental dig-up or contact with buried pipes or wires.

It is the law...CALL BEFORE YOU DIG

1-800-962-7962 or dial 811

General Attachment of Ledger Board to Band Board

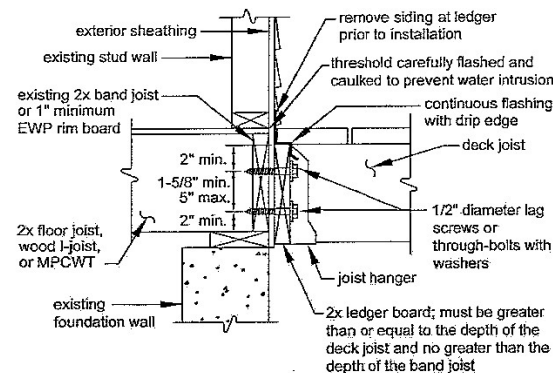

Pool decks

All pool decks, regardless of size or type, require a permit. They must be constructed to restrict direct access and provide a safety barrier to the pool area when the pool is not in use.

1. Fencing shall be at least 4 (four) feet in height, measured from grade or from the walking surface of other decks that are attached or adjacent to the pool deck. Generally, deck railings elevated above grade can be 36 (thirty-six) inches in height.

2. Railings or fencing must be constructed with openings not exceeding 4 (four) inches between any vertical or horizontal openings. Rails and deck structures shall not be constructed as to provide footholds, and railings shall be sufficiently secure to prevent movement.

3. Gates to the pool deck area shall be 4 (four) feet in height, self-closing, and latching. Pedestrian gates shall swing outward, but at no time can a gate swing over any steps other than over a landing area. Where the release mechanism of a self-latching device is located less than 54 (fifty-four) inches from the bottom of the gate, release mechanism and opening shall comply with the following:

- The release mechanism shall be located on the pool side of the gate, at least 3 (three) inches below the top of the gate.
- The gate and barrier shall have no opening greater than 1/2 inch around the latch for at least 18 (eighteen) inches around the latch mechanism.

4. All doorways to pool deck areas must be self-closing and latching.

5. Combination lock or keyed padlock required on the gate latch when pool is unattended.

6. Hot tubs or spas, when not in use, shall be covered with a solid, locking top.